

CAMWorks® Sync Manager

Synchronized Machining Made Easy!

- **Synchronized Simultaneous Machining** can be easily controlled using the new CAMWorks Sync manager. Multiple programs, or a single program with multiple channels, can be generated to reduce cycle times and increase productivity.

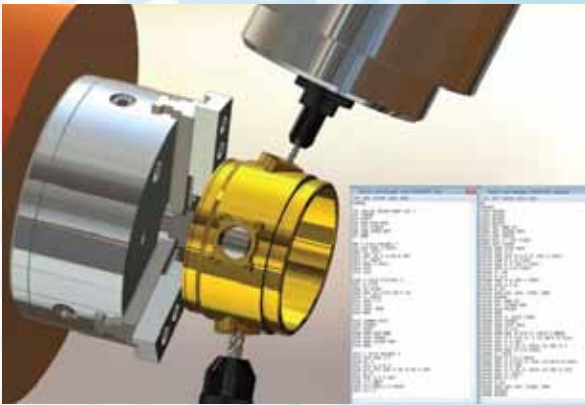

- **Drag and Drop Ease-of-Use** State of the art drop-and-drag technology makes it easy to move tools and operations from one turret to another and using the CAMWorks Sync Manager, the tool station number, cut direction, and toolpaths are all updated automatically!
- **Full Timing Code Support** Provides the ability to format, add, remove, and change the timing or sync

codes quickly and easily. Timing codes can be generated in a variety of formats and their position and increment are in full control of the user.

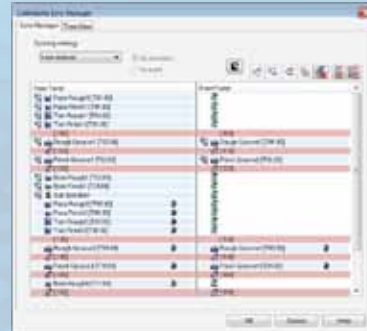

- **Multi-Tasking, Mill/Turn Support** CAMWorks Sync Manager includes full support for complex multi-tasking and mill/turn machines including 4 axis dual turret, dual spindle lathes as well as multi axis mill/turn machines with upper milling heads, lower turrets, and sub-spindles.

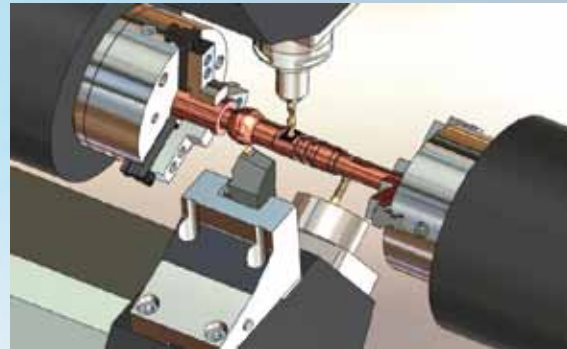

- **Reduce Shop Floor Setup Time** With CAMWorks Sync Manager, dry-runs for program validations are eliminated and set-up time is dramatically reduced. Once the program has been simulated, it is ready to run on the machine with confidence.
- **Interactive Time View** provides the user with the ability to clearly determine how much cycle time can be saved using synchronized operations and provides the ability to optimize the use of synchronized machining to reduce machining time and increase part quality.
- **Optional True G-code Machine Simulation** Once you've created your synchronized machining operations using the CAMWorks Sync Manager, use CAMWorks Virtual Machine to provide true G-code machine simulation directly from the G-code used to run the CNC machine. CAMWorks new Virtual Machine provides full support to process multiple programs/channels simultaneously to provide accurate machine simulation with collision detection.



About Geometric

Geometric is a specialist in the domain of engineering solutions, services and technologies. Its Geometry Technology Solutions (GTS) business unit develops cutting-edge point productivity solutions that enhance design and improve manufacturing operations. The end-user products from Geometric include CAMWorks®, eDrawings® Publisher, DFMPPro, GeomCaliper®, 3DPaintBrush™, CAMWorksXpress® and Glovius®. The key technologies from Geometric are NestLib®, Feature Recognition (FR), GeomDiff and 3DSearchIT®. Geometric licenses these technologies to OEM partners and also designs and implements customized process solutions using these technologies for industrial customers.

For further details about Geometric's GTS business unit, please visit www.geometricglobal.com/products or call +1.480.367.0132

The copyrights/trademarks of all products referenced herein, are held by their respective companies.

CAMWorks

To know more about this solution:

email: inquiries@camworks.com

Website: www.camworks.com